

MINITRIM 62 FIXED

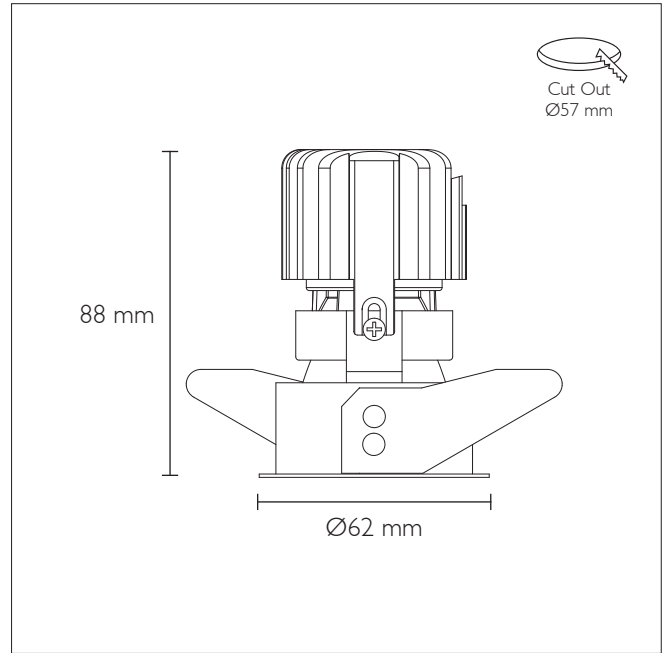
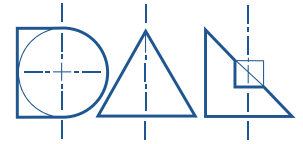

STANDARD MODULE - 27° / 34° / 47° / 56° Beam

CREE Lighting Engine - CRI 90, 2-Step MacAdam
2200K / 2700K / 3000K / 4000K

Source Lumens	System Wattage	Delivered Lumens	Efficacy (LOR 74%)	Delivered Lumens	Efficacy (LOR 81%)	Delivered Lumens	Efficacy (LOR 81%)	Delivered Lumens	Efficacy (LOR 78%)
		27°		34°		47°		56°	
1000 lm	7.2 W	765 lm	106 lm/W	835 lm	115 lm/W	832 lm	115 lm/W	801 lm	111 lm/W
1500 lm	11.1 W	1119 lm	100 lm/W	1221 lm	110 lm/W	1218 lm	109 lm/W	1172 lm	105 lm/W
1900 lm	15.0 W	1479 lm	98 lm/W	1613 lm	107 lm/W	1609 lm	107 lm/W	1549 lm	103 lm/W

Tested with CREE 3000K (System: 14.8 W / 400 mA)

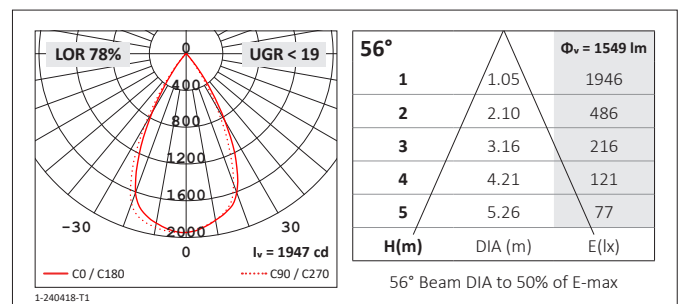
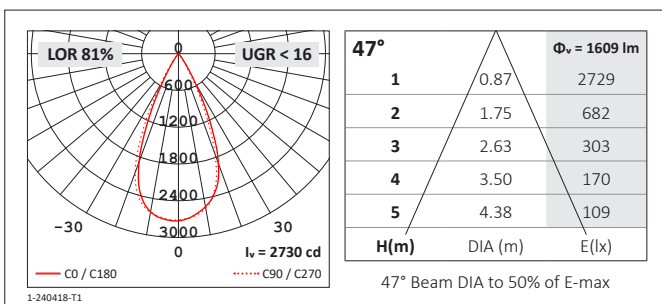
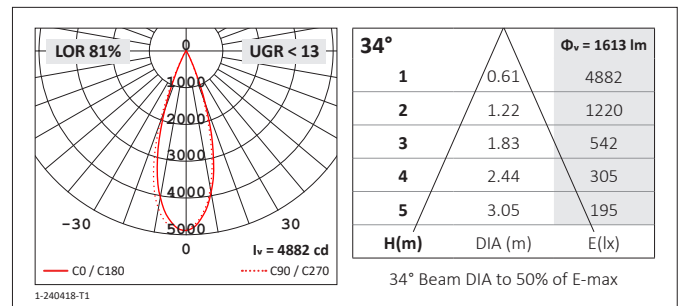
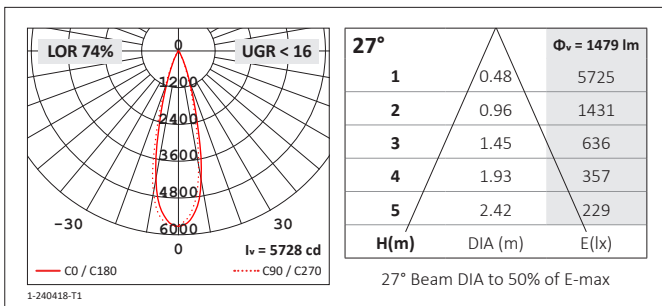

NARROW MODULE - 17° Beam

CREE Lighting Engine - CRI 90, 2-Step MacAdam
2200K / 2700K / 3000K / 4000K

Source Lumens	System Wattage	Delivered Lumens	Efficacy (LOR 80%)
17°			
700 lm	7.2 w	560 lm	77 lm/w
1000 lm	10.9 w	800 lm	73 lm/w
1300 lm	14.7 w	1040 lm	70 lm/w

Tested with CREE 4000K (System: 13.0 W / 350 mA)

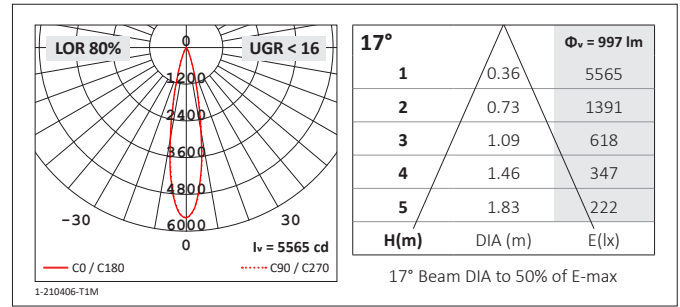

ULTRA NARROW MODULE - 12° Beam

CREE Lighting Engine - CRI 90, 2-Step MacAdam
2200K / 2700K / 3000K / 4000K

Source Lumens	System Wattage	Delivered Lumens	Efficacy (LOR 64%)
12°			
700 lm	8.5 w	448 lm	52 lm/w
1000 lm	13.7 w	640 lm	46 lm/w

Tested with CREE 4000K (System: 6.0 W / 175 mA)

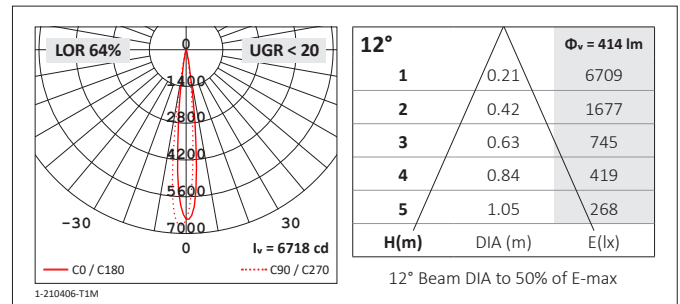

REFLECTOR COLOUR

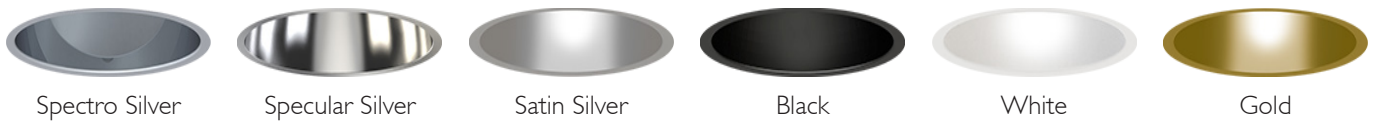

PRODUCT CODING EXAMPLE - F863113J550

Series	Beam	Reflector Colour	Source Lumens	LED	CCT	Driver Protocol	Emergency Protocol
F86	U 12°	1 Specular Silver	07 700 lm 10 1000 lm 13 1300 lm	J Cree	1 2200K 2 2700K 3 3000K 5 4000K	0 Fixed 1 1-10V 5 DALI 7 Lead / Trail 9 Addressable	0 None E Emergency N Non-maintained
IP20	1 17°	2 Satin Silver					
F87	2 27°	3 Black					
IP44	3 34°	4 White					
	4 47°	5 Gold					
	5 56°	8 Spectro Silver					
F86	3	1	13	J	5	5	0

- CRI 98 CREE Lighting engine is available on request
- Tolerance range for optical and electrical data shown in this datasheet: ±5%